

A Two-Color Laser Photolysis Method for Determining Reaction Rates of Short-Lived Intermediates by Product Analysis: Application to the *o*-Quinodimethane Problem

Akihiko Ouchi,^{*,†} Zhong Li,^{†,§} Masako Sakuragi,[†] and Tetsuro Majima[‡]

Contribution from the Research Institute for Green Technology, National Institute of Advanced Industrial Science and Technology, Tsukuba, Ibaraki 305-8565, Japan, and The Institute of Scientific and Industrial Research (SANKEN), Osaka University, Mihogaoka 8-1, Ibaraki, Osaka 567-0047, Japan

Received July 11, 2002; E-mail: ouchi.akihiko@aist.go.jp

Abstract: A time-delayed, two-color pulse laser photolysis technique was used for a kinetic study of short-lived transient species through product analysis, the determination of the rate constant of the cycloaddition of *o*-quinodimethane (**1**) and maleic anhydride (**2**) in room-temperature solutions. *o*-Quinodimethane (**1**) was generated from 1,2-bis[(phenylseleno)methyl]benzene (**3**) by the irradiation of a pulse of a KrF excimer laser (248 nm) in the presence of excess **2**, and a successive pulse of a XeCl excimer laser (308 nm) was irradiated to the reaction mixture after varied delay times from 0 to 0.1 s for the decomposition of the remaining **1** to quench the cycloaddition reaction. The rate constant of the cycloaddition of **1** and **2** was $2.1 \times 10^5 \text{ M}^{-1} \text{ s}^{-1}$, which was obtained by the analysis of the delay-time dependence of the product yields.

Introduction

Reactions of transient short-lived species have been studied by using various spectroscopic techniques. Although spectroscopic methods are very effective tools for such studies, the spectroscopic methods have some drawbacks such as (i) only spectroscopically observable species can be detected, (ii) limited applicability in the case of spectroscopic overlapping of different transient species, and (iii) quantitative information on the concentrations of the participating transient species is often difficult to obtain. Therefore, the developments of other experimental techniques that can avoid such spectroscopic difficulties provide a new means for extending the research field of transient short-lived species.

We report here an application of a time-delayed, two-color pulse laser photolysis technique¹ for the determination of a kinetic constant of a transient species through product analysis. We have selected the cycloaddition reaction of *o*-quinodimethane [**1**; 5,6-bis(methylene)cyclohexa-1,3-diene],² a thermally unstable short-lived intermediate, and maleic anhydride (**2**). *o*-Quinodimethane (**1**) is one of the extensively studied

intermediates, and many synthetic³ and physical⁴ works have been reported. Cycloaddition of **1** with alkenes and alkynes is one of the well-investigated fields,^{3,5} but the reported kinetic studies are mainly of some substituted *o*-quinodimethanes,⁶ and, to the best of our knowledge, the rate constant of the cycloaddition of parent **1** in room-temperature solutions has not been reported so far.

The lack of such important and basic kinetic data seems to be due to the difficulty for conducting the experiments by spectroscopic means. In the cycloaddition reactions, it is possible to observe the decay of **1** that is generated from conventional precursors by the flash photolysis technique because in most cases the absorption of **1** appears at a longer wavelength than

[†] National Institute of Advanced Industrial Science and Technology.

[‡] Osaka University.

[§] On leave of absence from the Institute of Pesticides and Pharmaceuticals, East China University of Science and Technology.

- (1) (a) Netto-Ferreira, J. C.; Wintgens, V.; Scaiano, J. C. *Tetrahedron Lett.* **1989**, *30*, 6851–6854. (b) Bendig, J.; Mitzner, R. *Ber. Bunsen-Ges. Phys. Chem.* **1994**, *98*, 1004–1008. (c) Ouchi, A.; Koga, Y. *Tetrahedron Lett.* **1995**, *36*, 8999–9002. (d) Ouchi, A.; Koga, Y.; Adam, W. *J. Am. Chem. Soc.* **1997**, *119*, 592–599 and references cited therein.
- (2) Reviews: (a) McCullough, J. J. *Acc. Chem. Res.* **1980**, *13*, 270–276. (b) Charlton, J. L.; Alauddin, M. M. *Tetrahedron* **1987**, *43*, 2873–2889. (c) Martin, N.; Seoane, C.; Hanack, M. *Org. Prep. Proced. Int.* **1991**, *23*, 237–272. (d) Segura, J. L.; Martín, N. *Chem. Rev.* **1999**, *99*, 3199–3246.

- (3) Reviews: (a) Sammes, P. G. *Tetrahedron* **1976**, *32*, 405–422. (b) Oppolzer, W. *Angew. Chem., Int. Ed. Engl.* **1977**, *16*, 10–23. (c) Oppolzer, W. *Synthesis* **1978**, 793–802. (d) Funk, R. L.; Vollhardt, K. P. C. *Chem. Soc. Rev.* **1980**, *9*, 41–61. (e) Kametani, T.; Nemoto, H. *Tetrahedron* **1981**, *37*, 3–16.
- (4) (a) Flynn, C. R.; Michl, J. *J. Am. Chem. Soc.* **1973**, *95*, 5802–5803. (b) Flynn, C. R.; Michl, J. *J. Am. Chem. Soc.* **1974**, *96*, 3280–3288. (c) Tseng, K. L.; Michl, J. *J. Am. Chem. Soc.* **1977**, *99*, 4840–4842. (d) Roth, W. R.; Biermann, M.; Dekker, H.; Jochems, R.; Mosselman, C.; Hermann, H. *Chem. Ber.* **1978**, *111*, 3892–3903. (e) Roth, W. R.; Scholz, B. P. *Chem. Ber.* **1981**, *114*, 3741–3750. (f) Chapman, O. L.; McMahon, R. J.; West, P. R. *J. Am. Chem. Soc.* **1984**, *106*, 7973–7974. (g) Trahanovsky, W. S.; Macias, J. R. *J. Am. Chem. Soc.* **1986**, *108*, 6820–6821. (h) Chapman, O. L.; Johnson, J. W.; McMahon, R. J.; West, P. R. *J. Am. Chem. Soc.* **1988**, *110*, 501–509. (i) Scaiano, J. C.; Wintgens, V.; Netto-Ferreira, J. C. *Pure Appl. Chem.* **1990**, *62*, 1557–1564. (j) Miranda, M. A.; Font-Sanchis, E.; Perez-Prieto, J.; Scaiano, J. C. *Chem. Commun.* **1998**, 1541–1542. (k) Catalani, L. H.; de Arruda Campos, I. P.; de Brito Rezende, D. *J. Photochem. Photobiol., A* **2001**, *140*, 1–5.
- (5) (a) Sato, H.; Isono, N.; Okamura, K.; Date, T.; Mori, M. *Tetrahedron Lett.* **1994**, *35*, 2035–2038. (b) de la Cruz, P.; de la Hoz, A.; Langa, F.; Illescas, B.; Martín, N.; Seoane, C. *Synth. Met.* **1997**, *86*, 2283–2284. (c) Jinno, M.; Kitano, Y.; Tada, M.; Chiba, K. *Org. Lett.* **1999**, *1*, 435 and references therein.
- (6) Takahashi, Y.; Miyamoto, K.; Sakai, K.; Ikeda, H.; Miyashi, T.; Ito, T.; Tabohashi, K. *Tetrahedron Lett.* **1996**, *37*, 5547–5550.

Scheme 1

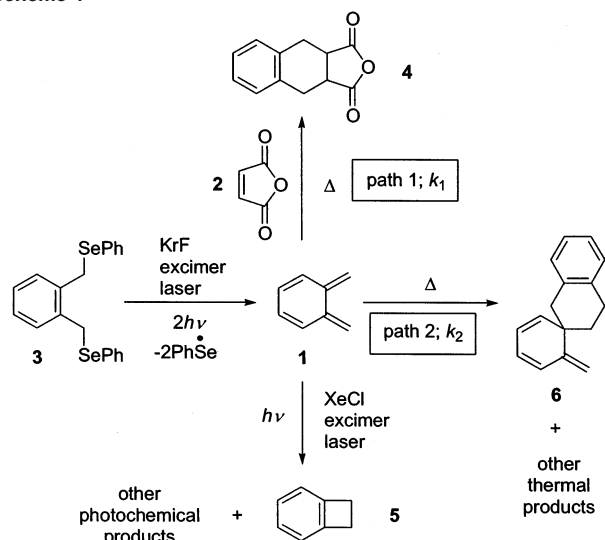

the precursors.⁷ However, the decay does not simply reflect the formation of the cycloadduct because **1** also gives other products, such as its dimers, oligomers, and polymers.⁸ There are also difficulties for tracing the formation of the cycloadduct spectroscopically because the absorption of the cycloadduct appears at the same wavelength region as the precursors (a large amount of the precursor remains intact even after the laser pulse irradiation due to their low photochemical efficiency⁹) and the above-mentioned dimers, oligomers, and polymers.

The strategy used in our experiment for the determination of the rate constant of the cycloaddition of **1** and **2** in room-temperature solutions was the fast and efficient generation of **1** by the first laser pulse irradiation and the quenching of the reaction by the decomposition of remaining **1** by the second laser pulse irradiation (Scheme 1).¹⁰ When **1** is generated by the irradiation of the first KrF laser pulse in the presence of **2**, the cycloaddition with **2** gives *cis*-1,2,3,4-tetrahydro-2,3-naphthalenedicarboxylic anhydride (**4**) (path 1 with the rate constant of k_1) together with thermal products of **1**,⁸ which are formed by second-order kinetics^{4b} (path 2 with the bulk rate constant of k_2). The reaction is quenched by the second XeCl laser pulse after a particular time in the course of the reaction to decompose remaining **1**, partly forming benzocyclobutene [**5**, bicyclo(4.2.0)octa-1,3,5-triene] as a photochemical product. By analyzing the delay-time dependence of the yield of **4**, as shown in the

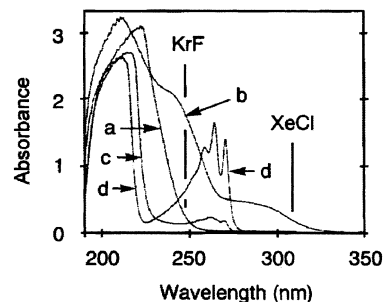

Figure 1. Absorption spectra of **2** (a), **3** (b), **4** (c), and **5** (d). Concentration, 10^{-4} M (**3**) and 10^{-3} M (**2**, **4**, **5**) in acetonitrile; optical path, 10 mm. The wavelengths of the KrF and XeCl laser emissions are indicated in the figure.

discussion, we can obtain the rate constant of the cycloaddition of **1** and **2**.

To the best of our knowledge, this is the first report on the determination of the rate constant of the cycloaddition of parent **1** with an alkene. The rate constant of the cycloaddition $\mathbf{1} + \mathbf{2} \rightarrow \mathbf{4}$ was found to be $2.1 \times 10^5 \text{ M}^{-1} \text{ s}^{-1}$.

Results

Precursor of 1. A necessary requirement for the precursor of **1** in our experiments is the high efficiency for the formation of **1** by a single laser pulse irradiation because detectable amounts of cycloadduct **4** are necessary for the product analysis. If the efficiency is low, several cycles of the time-delayed, two-color pulse irradiations are necessary to obtain a detectable amount of **4**, and this causes complication in the analysis of the reaction due to the secondary photochemical reactions involved in the successive photolysis cycles. We have selected 1,2-bis[(phenylseleno)methyl]benzene (**3**)¹¹ as the precursor in the time-delayed, two-color experiments because the photochemical efficiency of **3** for the formation of **1** by a single pulse of a KrF excimer laser ($1.25 \times 10^{21} \text{ photons m}^{-2} \text{ pulse}^{-1}$) was very high (chemical yield: 48%)^{12,13} as compared with the low efficiencies from the conventional precursors (chemical yield: < 9.4%),¹² which is not sufficient for our experiments.

Absorption Spectra. Figure 1 shows the absorption spectra of **2**, **3**, **4**, and **5**. The molar absorption coefficients (ϵ) of **2**, **3**, **4**, and **5** at 248 nm were 16 800, 160, 140, and $640 \text{ M}^{-1} \text{ cm}^{-1}$, and those at 308 nm were 1800, 10, 0, and $0 \text{ M}^{-1} \text{ cm}^{-1}$.^{10,12} The absorption of **1** has been reported^{4b,14} to have strong absorption at <240 nm, an absorption minimum at ca. 300 nm (ϵ 430), a maximum at 373 nm ($\epsilon > 3000$), and the absorption edge at ca. 430 nm. The ratio of the ϵ of **1** at 248 and 308 nm was reported to be 3.8:1.¹⁴

One-Color Excimer Laser Photolyses. Photolyses of 10^{-4} M **3** in the presence of 10^{-3} M **2** in acetonitrile were conducted by KrF (248 nm, $1.25 \times 10^{21} \text{ photons m}^{-2} \text{ pulse}^{-1}$) and XeCl (308 nm, $1.88 \times 10^{21} \text{ photons m}^{-2} \text{ pulse}^{-1}$) excimer lasers. The chemical yields of **4** and **5**, and the consumption of **3** by a pulse of the KrF laser, were 43, 4.1, and 91%, and those by the XeCl laser were 11, 0.3, and 42%, respectively.¹³ *o*-Quinodimethane spiro dimer [**6**, 3',4'-dihydro-6-methylenespiro(2,4-cyclohexa-

(7) The spectrum of **1** was measured in an EPA matrix at 77 K^{4b} (**1** was generated by the photolysis of 1,4-dihydrophthalazine) and in an argon matrix^{4c} (**1** was generated by a gas-phase reaction of α, α' -dibromo-*o*-xylene with sodium or potassium vapor). In flash photolysis studies, the generation and the decay of **1** were studied using 5,6-bis(methylene)bicyclo[2.2.1]-hept-2-en-7-one^{4d} and 2-indanone⁴ⁱ as precursors.

(8) For example: (a) Cava, M. P.; Deana, A. A. *J. Am. Chem. Soc.* **1959**, *81*, 4266–4268. (b) Errede, L. A. *J. Am. Chem. Soc.* **1961**, *83*, 949–954. (c) Sisido, K.; Kusano, N.; Noyori, R.; Nozaki, Y.; Simosaka, M.; Nozaki, H. *J. Polym. Sci., Part A: Polym. Chem.* **1963**, *1*, 2101–2107.

(9) The conventional precursors for the generation of **1** often used so far are 1,4-dihydrophthalazine (**8**),^{4a,b} 2-indanone (**9**),⁴ⁱ 3-isochromanone (**10**),^{2d} sultine [**11**: 1,4-dihydro-2,3-benzoxathiin 3-oxide],^{2d} and 1,3-dihydroisothionaphthene 2,2-dioxide (**12**).^{2d} However, **8** is reported to be unstable at room temperature and can be only handled at low temperature. Compounds **9–12** have absorptions at shorter wavelengths than 270 nm so that a KrF (248 nm) excimer laser was used for the generation of **1**. It is revealed that the consumption of **9–12** in 10^{-4} M acetonitrile solutions by the irradiation of a single pulse of a KrF ($1.25 \times 10^{21} \text{ photons m}^{-2} \text{ pulse}^{-1}$) excimer laser was <9.4%.¹²

(10) Ouchi, A.; Koga, Y. *J. Org. Chem.* **1998**, *63*, 6780–6781.

(11) (a) Ouchi, A.; Koga, Y. *Chem. Commun.* **1996**, 2075–2076. (b) Ouchi, A.; Koga, Y. *J. Org. Chem.* **1997**, *62*, 7376–7383.

(12) Ouchi, A.; Sakuragi, M.; Kitahara, H.; Zandomenighi, M. *J. Org. Chem.* **2000**, *65*, 2350–2357.

(13) The yield is based on the starting material.

(14) Fujiwara, M.; Mishima, K.; Tamai, K.; Tanimoto, Y.; Mizuno, K.; Ishii, Y. *J. Phys. Chem. A* **1997**, *101*, 4912–4915.

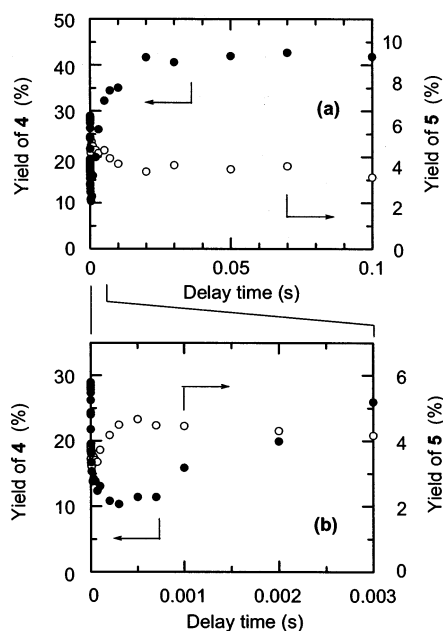

Figure 2. Chemical yields¹³ of **4** and **5** in the time-delayed, two-color photolysis as a function of the delay time between the KrF and XeCl lasers. Delay time: 0–0.1 s (a) and 0–0.003 s (b). ●, **4**; ○, **5**. Concentration: 10^{-4} M **3** and 10^{-3} M **2** in acetonitrile. Laser fluence: 1.25×10^{21} (KrF) and 1.88×10^{21} (XeCl) photons m^{-2} pulse⁻¹. Optical path: 1 mm. The jitter between the KrF and XeCl laser pulses was ± 3 ns.

diene-1,2'(1'*H*)-naphthalene)] was not detected in the product mixtures, although **6** was observed in the laser photolyses of **3** in the absence of **2**.¹² However, some unidentified peaks were observed in reverse phase HPLC analyses, and silica gel TLC analyses also showed the existence of a significant amount of unidentified compounds at the origin. These compounds are expected to be oligomers and polymers generated from **1**.⁸

Time-Delayed, Two-Color Excimer Laser Photolyses. The two-color photolyses were conducted by one pair of laser pulse irradiations; the photolysis was conducted by one pulse of the KrF excimer laser and one subsequent pulse of the XeCl excimer laser that was flashed after various delay times (0–0.1 s).

Figures 2 shows the chemical yields¹³ of **4** and **5** as a function of the delay time of the two laser pulses in the time-delayed, two-color photolyses. The consumption of **3** in the two-color photolyses (91–95%)¹³ was independent of the delay times and almost the same as that in the one-color KrF laser photolysis (91%). This indicates that the consumption of **3** proceeded mainly by the KrF laser. On the contrary, the yields of **4** and **5** were much dependent on the delay time of the second XeCl laser pulse. A maximum for the yield of **5** and a minimum for the yield of **4** were observed at the delay time of ca. 0.3 ms (cf., Figure 2b). However, after the delay time of ca. 20 ms, the yields of **4** and **5** returned to the same level as those of the one-color KrF laser photolysis (cf., Figure 2a). As seen in Figure 2, the time scale of the recovery of **4**, 0.3–20 ms, was much longer than that of the decrease of **4**, 0–0.3 ms.

The existence of the maximum for the chemical yield of **5** indicates that the highest concentration of **1** was reached at 0.3 ms delay time and the decrease of **1** by further reactions started from this point.

Comparison of the HPLC data on the photolysis of **3** in the presence and absence of **2** showed that the peak corresponding to **4** was practically the only new peak that appeared by the

Scheme 2

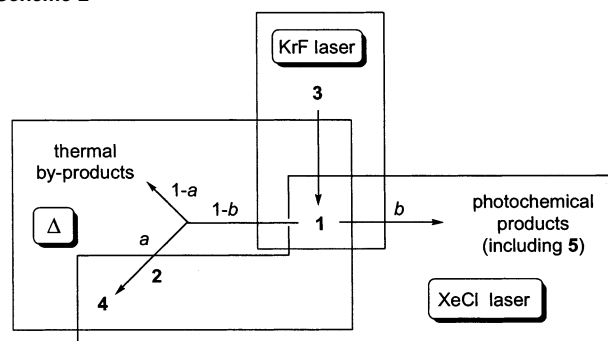

addition of **2**. This indicates that **4** was the only product formed by the reaction of **1** and **2**. The absence of **6** and the presence of unidentified by-products observed in the HPLC and TLC analyses were similar to those in the one-color excimer laser photolyses.

Photochemical Stability of 4 and 5. Photolyses of **4** in 10^{-4} M acetonitrile showed no decomposition of **4** by a pulse of the KrF or XeCl lasers under the same reaction conditions as those in the one-color laser photolyses of **3**. This indicates that the delay-time dependence on the yield of **4** is only due to its formation and not to its decomposition. It is also reported that **5** is stable under the same photolysis condition of the KrF or XeCl lasers.¹²

Discussion

To obtain the rate constant of cycloaddition $\mathbf{1} + \mathbf{2} \rightarrow \mathbf{4}$, k_1 , by the analysis of the delay-time dependence of the yield of **4**, we have to understand the reaction path of **1** and the time profiles of **1**, **4**, and **5**. Although some unidentified products were observed in the two-color laser photolyses of **3** both in the presence and in the absence of **2**, it was found that **4** was the only new product that appeared by the addition of **2**. This implies that the products other than **1** generated by the photolysis of **3** do not affect successive reactions of **1**. Therefore, we only have to consider the thermal (with and without **2**) and photochemical reactions of **1**.

Reaction Paths of 1. Scheme 2 shows the reaction paths of **1** in the time-delayed, two-color photolysis. Before the second XeCl laser pulse, **1**, which is generated by the first KrF laser pulse, undergoes thermal processes that partly give **4** (100%, $0 \leq a \leq 1$) by the cycloaddition with **2**, and the rest forms other thermal products of **1** [$100(1 - a)\%$]. When the second XeCl laser pulse is irradiated, a part of the remaining **1** ($100b\%$, $0 \leq b \leq 1$) undergoes photochemical processes, and the rest [$100(1 - b)\%$] proceeds by thermal processes.

The decomposition of **4** by the second XeCl laser can be excluded because the control experiments showed no decomposition of **4** by the XeCl laser irradiation.

Time Profile of 1, 4, and 5. Scheme 3a shows schematically the time profile of **1**, **4**, and **5** in the one-color KrF laser photolysis, and Scheme 3b shows those in the time-delayed, two-color photolysis. As shown in Scheme 3a, **1** and **5** are generated by a pulse of the KrF laser (at $t = 0$) from **3** with the initial concentrations of $[\mathbf{1}]_0$ and $[\mathbf{5}]_s$, respectively.^{10,12} The concentration of **5** does not change in the course of the reaction because **5** is stable in room-temperature solutions. On the contrary, **1** undergoes cycloaddition with **2** to give **4**. When

Scheme 3

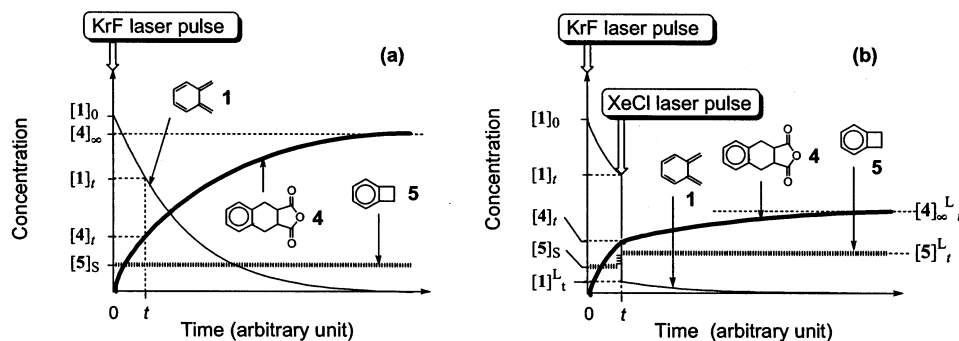

the concentrations of **1** and **4** at time t are $[1]_t$ and $[4]_t$, respectively, we obtain

$$[4]_t = a([1]_0 - [1]_t) \quad (a: \text{const.}; 0 \leq a \leq 1) \quad (1)$$

At $t = \infty$, where the concentration of **4** is $[4]_\infty$, eq 1 becomes eq 1' because $[1]_\infty = 0$.

$$[4]_\infty = a[1]_0 \quad (1')$$

Scheme 3b shows the time profiles of **1**, **4**, and **5** in the time-delayed, two-color photolysis. When the second XeCl laser is irradiated at the delay time of t , the concentrations of **1** and **5** immediately change from $[1]_t$ to $[1]_t^L$ and from $[5]_s$ to $[5]_t^L$, respectively, by photochemical reactions. Thus, we obtain

$$[1]_t^L = (1 - b)[1]_t \quad (b: \text{const.}; 0 \leq b \leq 1) \quad (2)$$

The final concentration of **4**, $[4]_\infty^L$, is shown as

$$[4]_\infty^L = [4]_t + a[1]_t^L \quad (3)$$

Thus, eqs 1, 1', 2, and 3 are reduced to

$$[1]_t = \frac{[4]_\infty - [4]_\infty^L}{ab} \quad (4)$$

Equation 4 indicates that the value ($[4]_\infty - [4]_\infty^L$) is proportional to $[1]_t$, the concentration of **1** at delay time t .

Determination of Parameters a and b . The yield of **1** obtained from 10^{-4} M **3** in acetonitrile solution by the irradiation of a pulse of the KrF excimer laser is reported to be 48%¹³ under the same experimental conditions as those of the present experiments.¹² Therefore, we obtain $[1]_0 = 4.8 \times 10^{-5}$ M. The value $[4]_\infty$ can be calculated from the yield of **4** in the one-color KrF excimer laser photolysis, which is $[4]_\infty = 4.3 \times 10^{-5}$ M (43% yield from 10^{-4} M **3** and 10^{-3} M **2**). From eq 1' and the values $[1]_0$ and $[4]_\infty$, we obtain

$$a = \frac{[4]_\infty}{[1]_0} = 0.90$$

The result indicates that the selectivity of reaction **1** + **2** → **4** in the thermal reactions of **1** was 90%.

The ratio of photochemical to thermal processes by the irradiation of the second XeCl laser pulse is indicated by

$b: (1 - b)$. From eqs 1' and 4 at $t = 0$, the value b is shown as

$$b = \frac{[4]_\infty - [4]_\infty^L}{[4]_\infty} \quad (5)$$

The concentration $[4]_\infty^L$ is related to the yield of **4** at the delay time of 0 (in practice, at the delay time of 0.3 ms in Figure 2 where the concentration of **1** reached its maximum). The yield of **4** at $t = 0$ was 10% so that $[4]_\infty^L = 1.0 \times 10^{-5}$ M. By substituting values $[4]_\infty^L$ and $[4]_\infty (= 4.3 \times 10^{-5}$ M) into eq 5, we obtain

$$b = 0.77$$

This value of b indicates that the ratio of the photochemical to thermal processes of **1** by the irradiation of a pulse of the XeCl laser was 77:23. This ratio is in good accord with that obtained in the photolysis of **3** in the absence of **2**, that is, 81:19.¹²

Determination of the Rate Constant for the Cycloaddition of **1 and **2** in Room-Temperature Solution.** We have shown that **4** was the only product obtained by the reaction of **1** and **2**. The decay of **1** in the absence of dienophiles follows second-order kinetics, which is reported by spectroscopic^{4d,g,i} and time-delayed, two-color photolysis¹² experiments. Therefore, we obtain a kinetic equation on **1** as

$$-\frac{d[1]_t}{dt} = k_1[2]_t[1]_t + k_2[1]_t^2 \quad (6)$$

where $[1]_t$ and $[2]_t$ are the concentrations of **1** and **2** at time t , k_1 is the rate constant of the cycloaddition **1** + **2** → **4**, and k_2 is the rate constant of the second-order decay of **1** (cf., Scheme 1).

As we can approximate $[2]_t$ as a constant ($[2]_t \approx [2]_0$), because $[2]_t \gg [1]_t$, eq 6 can be solved¹⁵ as

$$\frac{1}{[1]_t} = \left(\frac{k_2}{k_1[2]_t} + \frac{1}{[1]_0} \right) \exp(k_1[2]_t t) - \frac{k_2}{k_1[2]_t} \quad (7)$$

The second-order rate constant, k_2 , is reported to be $9.94 \times 10^3 \text{ M}^{-1} \text{ s}^{-1}$ at 25 °C, which was obtained by a spectroscopic method.^{4g,16} By substituting the values k_2 , $[2]_t (\approx [2]_0 = 10^{-3}$

(15) When $[2]_t$ is a constant, eq 6 becomes a Bernoulli's differential equation, which can be easily solved. Derivation of eq 7 from eq 6 is shown in the Supporting Information.

(16) The reported second-order rate constant^{4g} is thought to be dimerizations of **1**; however, we have revealed that other reactions are also involved in the second-order decay of **1**.¹²

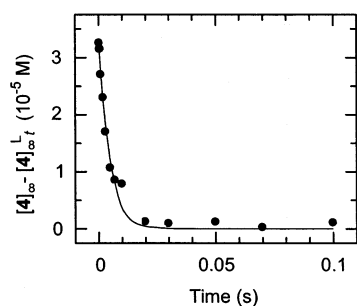
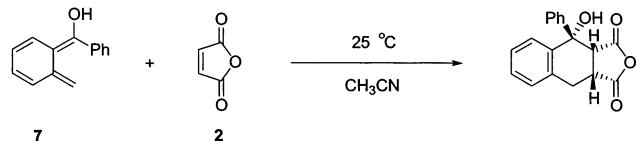

Figure 3. Plots of $([AD]_{\infty} - [AD]_{\infty}^L_t)$ as a function of t with curve fitting according to eq 8.

Scheme 4



M), $[1]_0 (=4.8 \times 10^{-5} \text{ M})$, $a = 0.90$, $b = 0.77$, and eq 4 to eq 7, we obtain

$$[4]_{\infty} - [4]_{\infty}^L_t = \frac{0.69}{\left(\frac{9.94 \times 10^6}{k_1} + \frac{10^5}{4.8}\right) \exp(10^{-3}k_1t) - \frac{9.94 \times 10^6}{k_1}} \quad (8)$$

Figure 3 shows the plots of $([4]_{\infty} - [4]_{\infty}^L_t)$ as a function of delay time, t , which was calculated from the values in Figure 2. The solid curve in Figure 3 shows the result on the curve fitting according to eq 8;¹⁷ the room-temperature rate constant k_1 obtained by the curve fitting was $2.1 \times 10^5 \text{ M}^{-1} \text{ s}^{-1}$.

The rate constant of the cycloaddition of substituted *o*-quinodimethane **7** and **2** (Scheme 4) in acetonitrile has been reported to be $2.2 \times 10^6 \text{ M}^{-1} \text{ s}^{-1}$,⁶ which is ca. 10-fold larger than that of **1**. However, this difference may be explained by the acceleration of the cycloaddition reaction due to the substituent effects.

Conclusion

A time-delayed, two-color pulse laser photolysis technique was used for a kinetic study of short-lived transient species through product analysis, the determination of the rate constant of the cycloaddition of **1** and **2** in room-temperature solutions. *o*-Quinodimethane (**1**) was generated from **3** by the irradiation of a pulse of a KrF excimer laser (248 nm) in the presence of excess **2**, and a successive pulse of a XeCl excimer laser (308 nm) was irradiated to the reaction mixture after varied delay times from 0 to 0.1 s for the decomposition of the remaining **1**

(17) The Levenberg–Marquardt algorithm was used for the curve fitting, which was conducted by using a computer program ORIGIN version 6.1J, produced by MICROCAL Software, Inc.

to quench the cycloaddition reaction. The rate constant of the cycloaddition of **1** and **2** was obtained by the analysis of the delay-time dependence of the product yields; the rate constant obtained was $2.1 \times 10^5 \text{ M}^{-1} \text{ s}^{-1}$.

Experimental Section

Compounds **3**, **4**, **5**, and **6** were synthesized according to the reported procedures.^{11b,12} Maleic anhydride (**2**) was purchased from Wako Chemicals, and spectroscopic grade acetonitrile was from Cica-Merck/Kanto Chemicals.

Time-Delayed, Two-Color Photolyses. The reactions were conducted in 0.05 mL of an acetonitrile solution of 10^{-4} M **3** and 10^{-3} M **2** under a nitrogen atmosphere at room temperature by using a synthetic quartz cuvette of 10 mm width and 1 mm optical path. The first laser pulse was generated by a Lambda Physik EMG 201 MSC [KrF, $1.25 \times 10^{21} \text{ photons m}^{-2} \text{ pulse}^{-1}$ ($100 \text{ mJ cm}^{-2} \text{ pulse}^{-1}$), pulse width (fwhm): 30 ns], and the second pulse was generated by a Lambda Physik EMG 102 MSC [XeCl, $1.88 \times 10^{21} \text{ photons m}^{-2} \text{ pulse}^{-1}$ ($121 \text{ mJ cm}^{-2} \text{ pulse}^{-1}$), pulse width (fwhm): 14 ns] excimer laser. The pulse energy was measured by a Gentec ED-500 joulemeter and a Tektronic T912 10 MHz storage oscilloscope. The delay time was defined as the time between two peaks of the KrF and XeCl laser pulses and varied from 0 ns to 0.1 s. The delay times between the two laser pulses were controlled by a Stanford Research Systems DG535 four-channel digital delay/pulse generator. The delay times of the two laser pulses were measured with a Hamamatsu Photonics R1193U-55 biplanar phototube and an Iwatsu Electric TS-8123 storage scope. The consumption of **3** and the yields of **4**, **5**, and **6** were obtained from the average of two independent runs.

One-Color Excimer Laser Photolyses and Decomposition of **4 and **5**.** The photolyses of 10^{-4} M **3** in the presence of 10^{-3} M **2**, and those of 10^{-4} M **4** and **5**, were conducted with an excimer laser using the same experimental setup and procedure as those of the time-delayed, two-color laser photolysis. The fluence of the lasers was the same as that in the two-color experiments. The results were obtained from the average of three independent runs.

Analyses of the Products. The yields of **4**, **5**, and **6**, and the consumption of **3**, were determined by HPLC analysis (detection wavelengths of UV detectors: 254 and 300 nm) on a Merck Supersphere 60 RP-8e column (244 mm \times 4 mm i.d.), and their retention times were compared with authentic samples.

Acknowledgment. We thank the Agency of Industrial Science and Technology for financial support. Z.L. thanks the Agency of Industrial Science and Technology for the ITIT and AIST fellowships.

Supporting Information Available: Derivation of eq 4 from eqs 1, 1', 2, and 3, and derivation of eq 7 from eq 6 (PDF). This material is available free of charge via the Internet at <http://pubs.acs.org>.

JA027653V